

Verge V-Boom™ Gate



Verge V-Boom Gates™ are the perfect solution where forklift access across a walkway is required. When the gate is opened to allow forklift access, the gate swings across the walkway, temporarily blocking pedestrian access. When closed, the walkway is protected and can be used as normal. Ideal where walkways cross roller doors or forklift thoroughfares.

To reduce risk of workplace injuries, forklift/pedestrian interaction should be kept to a minimum. The V-boom gate helps you to achieve this. The less shared intersections you have, means less risk of accidents!



Features and Benefits

- ✓ Stand alone – includes 2 x steel posts
- ✓ All fixings included
- ✓ Suitable for internal and external use
- ✓ Easily customisable for reduced widths
- ✓ Easy to assemble and install
 - no cutting, no welding, no mess
- ✓ 10 Year Warranty
- ✓ Manufactured in Australia

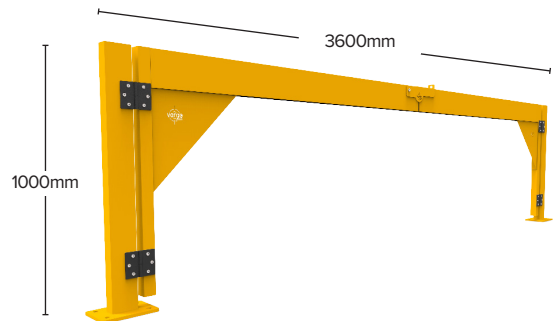

Specifications

	BV065	BV066	BV067
Gate width	1800mm	1800mm	3600mm
Overall width	2038mm	2038mm	3857mm
Orientation (hinge mount)	Left hand	Right hand	Double
Unit weight	45kg	45kg	64kg
Post specifications	1000mm H - 100 x 50 x 2mm mild steel		
Post base plate	220 x 160 x 12mm mild steel		
Post fixings	4 x M16 x 105mm through bolts (per post)		
Gate Panel	1850 x 950mm		
Gate furniture	HD Steel hinges		
Finish	Powdercoat yellow		



1800 765 539



sales@verge.com.au



vergesafetybarriers.com.au